

SERVICE BULLETIN NO. RSB1078-180

I. TECHNICAL DETAILS

1.1 Category:

Recommended

1.2 Airplanes affected:

Bezeichnung / Description	LBA Kennblatt-Nr. TCDS	EASA TCDS	FAA TCDS	Serial-Nr.
G 115E	1078	EASA.A.364		All S/N
G 115EG	1078	EASA.A.364	A57EU	All S/N

1.3 Time of Compliance:

On holders discretion

1.4 Subject:

ATA-Code: 32-50 Nose Wheel Steering
Improved attachment of shimmy damper

1.5 Reason:

To improve the service time of the shimmy damper a new attachment is introduced.

1.6 Concurrent documents:

-

1.7 Approval Note:

The technical content of this document is approved under the authority of EASA Design Organization Approval No. EASA.21J.030.

These information or instructions relate to change no. MÄM1078-135 which has been approved under the authority of EASA Design Organisation Approval No. EASA.21J.030.

1.8 Accomplishment/ Instructions

- 1.8.1 Ensure that the aircraft is safe for parking I.A.W. AMM chapter 10-10.
- 1.8.2 Remove the shimmy damper I.A.W AMM chapter 32-50.
- 1.8.3 Remove bearing assembly 115-5230.
- 1.8.4 Attach new bearing unit 115E-5230 (item 1) with bolts, washers and nuts (items 2-5) according to drawing below.
- 1.8.5 If RI1078-29/1 is applied, do not use washers DIN9021-A2-5.3 (item 5).
- 1.8.6 Lift the aircraft on jacks I.A.W. AMM chapter 07-10.
- 1.8.7 Install the shimmy damper (item 6) with additional lock nut 115-5225.04 (item 8) and rings 115E-5200.15 (item 7) to bracket.
- 1.8.8 Attach the shimmy damper to the steering actuator lever I.A.W AMM chapter 32-50.

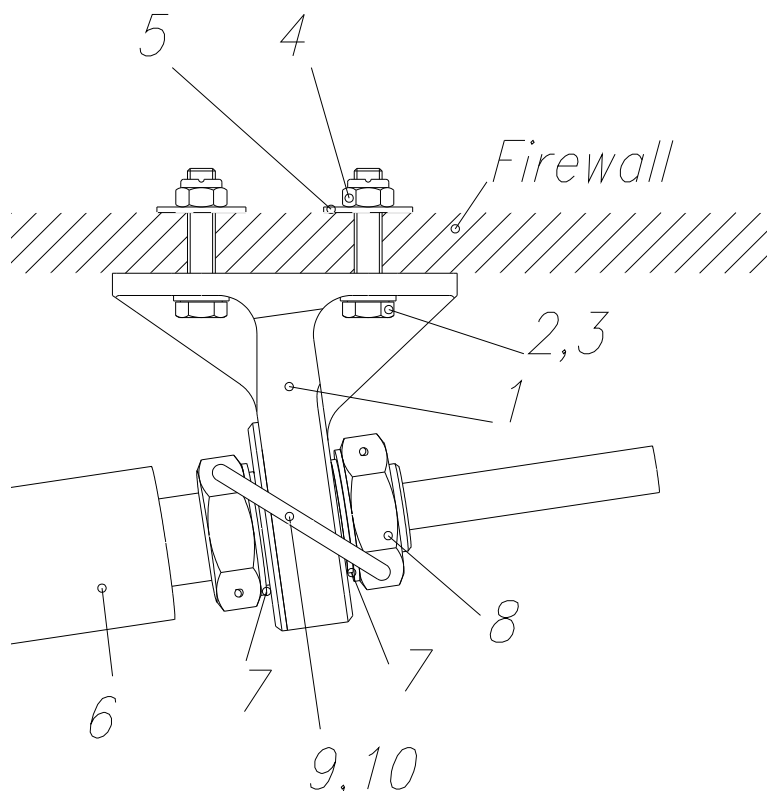

- 1.8.9 Do a test for range of movement of the nose wheel steering control:
- Turn the nose leg by hand as far as possible in each direction. The nose wheel must turn to hit the stops in each direction.
- 1.8.10 If necessary, adjust the lock-nuts to provide full nose wheel movement.
- 1.8.11 Tighten lock-nuts well. Secure inner lock-nut with thread locking adhesive GS513005. Ensure that no GS513005 is on the bearing.
- 1.8.12 Secure nuts using locking wire (item 9). Use sleeve (item 10) to protect locking wire from chafing. Mark outer lock-nut with inspection lacquer GS513010.
- 1.8.13 Do a test for correct range of movement of the rudder control and the steering control I.A.W. AMM chapter 27-20. The nose wheel must turn equally in each direction $9^{\circ} \pm 1^{\circ}$.
- 1.8.14 Lower the aircraft with the jacks I.A.W. AMM chapter 07-10
- 1.8.15 Install the engine cowlings I.A.W. AMM chapter 71-10
- 1.8.16 Release aircraft to service.

1.9 Repetitive Actions

Until the corresponding Maintenance Manuals are corrected within the next regular revision, an additional inspection item has to be entered handwritten into the AMM Chap. 05-20.

	Do this work at -----these flight hours>	50	100	200	Other Check	See Chapter
2.38	Aircraft with RSB1078-180 installed: - Examine the protective sleeve and the locking wire, replace if necessary. - Check inspection lacquer on outer lock-nut, tighten and secure lock-nuts if marking is damaged	X	X	X		

II. PLANNING INFORMATION

2.1 Weight and CG

N/A

2.2 Material and Availability

Item	Part Number	Description	Qty.	Supplied with Mod.Kit
1	115E-5230	Bearing Unit	1	Yes
2	LN9037-M5x24	Bolts	4	Yes
3	LN9025-5.3	Washer	4	
4	LN9348-M5	Nut	4	
5	DIN9021-A2-5.3	Washer	A/R	
6	115-5225/1	Shimmy damper	1	
7	115E-5200.15	Ring	2	Yes
8	115-5225.04	Lock-nut	1	Yes
9	MS 20995C-25	Locking wire	A/R	
10	HIS-A-3/1 3mm clear (HellermannTyton)	Sleeve	A/R	Yes
11	GS513005	Thread locking adhesive (Loctite 638)	A/R	
12	GS513010	Inspection lacquer	A/R	

2.3 Special Tools

N/A

2.4 Labor costs

N/A

2.5 Reference documents

N/A

2.6 Credit

N/A



III. REMARKS

- The correct execution of the instructions in paragraph 1.8 may be performed by a competent person/an authorized aviation workshop or at the manufacturer and has to be certified in the logbook by an authorized inspector.
- If you have sold your aircraft in the meantime, would you kindly pass this information on to the new owner and forward his address and aircraft S/N to us.
- For questions and assistance please contact:

Rudi Vodermeier , Head of Product Support,
phone: +49 8268 998139
fax: +49 8268 998200
e-mail: productsupport@grob-aircraft.com